

DESIGN AND CONSTRUCTION OF A SLIM FLAT WALL (SFW) AQUARIUM MODEL AS A PROMOTIONAL ORNAMENTAL FISH CONSERVATION MEDIA FOR MINIMALIST BUILDINGS

Rancang Bangun Model *Slim Flat Wall (Sfw) Aquarium* Sebagai Media Konservasi Ikan Hias Promotif untuk Bangunan Minimalis

Kaminton Tambunan^{1*}, Raman G.T.H. Simanjuntak², Novie Wijaya², Andie Murtono², Dwi Dharma Arta Kusuma², Ahmad Ilham Ramadhani², Mukhlis², Muhamad Amril Idrus², Febi Luthfiani²

¹Fisheries Mechanization Study Program, Bitung Marine and Fisheries Polytechnic

²Fisheries Mechanization Study Program, Kupang Marine and Fisheries Polytechnic

Tandurusa Aertembaga Street, Bitung City, North Sulawesi

*Corresponding Author : kamintonkkp@gmail.com

(Received March 2nd 2026; Accepted March 6th 2026)

ABSTRACT

This study developed a Slim Fit Wall (SFW) Aquarium as a medium for ornamental fish conservation and a decorative element for minimalist buildings. The aquariums were designed to be slim with dimensions of 80 × 10 × 40 cm and 100 × 10 × 60 cm, using glass materials and lightweight steel brackets. This design offers a space-saving solution without sacrificing visual and functional aspects. Testing involved strength simulations using Autodesk Inventor software, demonstrating Von Mises stresses below the material's safe limit, ensuring structural strength. Visual and functional tests were conducted with respondents from the KP Kupang Polytechnic. The results showed an average visual satisfaction level of 83.9%, with advantages in space efficiency and visual comfort. Functionality was tested for one month, demonstrating stable performance without component damage. The study's conclusion confirms that the SFW Aquarium is suitable for minimalist buildings, fulfilling aesthetic needs, and supporting conservation awareness. Further research is recommended to explore variations in size and design.

Keywords: Slim Fit Wall Aquarium, Conservation, Ornamental Fish

ABSTRAK

Penelitian ini mengembangkan Slim Fit Wall (SFW) Aquarium sebagai media konservasi ikan hias dan elemen dekoratif untuk bangunan minimalis. Akuarium dirancang ramping dengan ukuran 80 × 10 × 40 cm dan 100 × 10 × 60 cm, menggunakan material kaca dan bracket baja ringan. Rancangan ini menawarkan solusi hemat ruang tanpa mengorbankan aspek visual dan fungsi. Pengujian melibatkan simulasi kekuatan menggunakan perangkat lunak Autodesk Inventor, menunjukkan tegangan Von Mises di bawah batas aman material, memastikan

kekuatan struktur. Visual dan fungsionalitas diuji dengan responden dari Politeknik KP Kupang. Hasilnya, tingkat kepuasan visual rata-rata mencapai 83,9%, dengan keunggulan pada efisiensi ruang dan kenyamanan visual. Fungsionalitas diuji selama satu bulan, menunjukkan kinerja stabil tanpa kerusakan komponen. Kesimpulan penelitian menegaskan bahwa SFW Aquarium cocok untuk bangunan minimalis, memenuhi kebutuhan estetika, dan mendukung kesadaran konservasi. Penelitian selanjutnya direkomendasikan untuk mengeksplorasi variasi ukuran dan desain.

Kata kunci: Slim Fit Wall Aquarium, Konsevasi, Ikan Hias

INTRODUCTION

One of the Ministry of Maritime Affairs and Fisheries' (MMAF) priority programs for 2024 is the expansion of marine conservation areas. This priority program aims to realize one of the MMAF's missions: protecting the ocean and its resources (MMAF, 2024). One way to support this priority program is through promotional activities or media that serve to introduce the richness of marine resources while raising public awareness of the importance of conservation and ensuring the sustainability of these resources.

This is also emphasized in Ministerial Regulation No.17/Permen-KP/2020 concerning the MMAF Strategic Plan for 2020-2024, which states that in the policy direction "Management of marine areas, coasts, and small islands, as well as strengthening supervision of marine and fisheries resources and fish quarantine through coordination with relevant agencies," one strategy is to improve the management of protected, preserved, and/or utilized aquatic biodiversity. Furthermore, it aligns with the Sustainable Development Goals (SDGs) for marine ecosystems, one of which is to increase economic benefits from the sustainable use of marine resources, including through fisheries management, aquaculture, and sustainable tourism (MMAF, 2020). One marine resource utilized for recreation or tourism is ornamental fish.

Aquariums are a popular promotional medium for fish conservation, a marine resource popular among the general public. Aquariums serve three functions simultaneously: conservation, education (promotion), and recreation regarding fish biodiversity (Marchio, 2018). Therefore, aquariums fulfill the requirements to be used as a promotional medium to raise public awareness of the importance of fish conservation while also providing a recreational aspect needed by modern society, namely the need for "healing" (Clements *et al.*, 2019).

However, aquariums have historically faced constraints due to their size and placement within buildings, which take up significant space. To meet the desired recreational needs, medium to large aquariums are naturally preferred due to their greater visual satisfaction. However, limited space in today's minimalist buildings often forces users to opt for mini aquariums (Arif *et al.*, 2018).

To maximize visual satisfaction while maintaining minimal space requirements in minimalist buildings, this research will create and develop a slim, flat-wall (SFW) aquarium. This idea was inspired by the growing use of slim flat-screen TVs, which are now widely used and have successfully replaced conventional, space-consuming TVs.

It is hoped that this SFW aquarium model will encourage more people to own aquariums, especially in urban areas with limited living space. This will encourage more people to pay more attention to fish conservation and maximize the recreational benefits of aquariums. Furthermore, it is hoped that in the future, MSMEs focused on the SFW aquarium business will grow, creating jobs and increasing economic value in the fisheries sector, particularly in ornamental fish.

RESEARCH METHODS

This research is applied research with a level 6 technological readiness level (TKT), with outputs in the form of product models or prototypes tested in a relevant environment. The research flowchart is as follows.

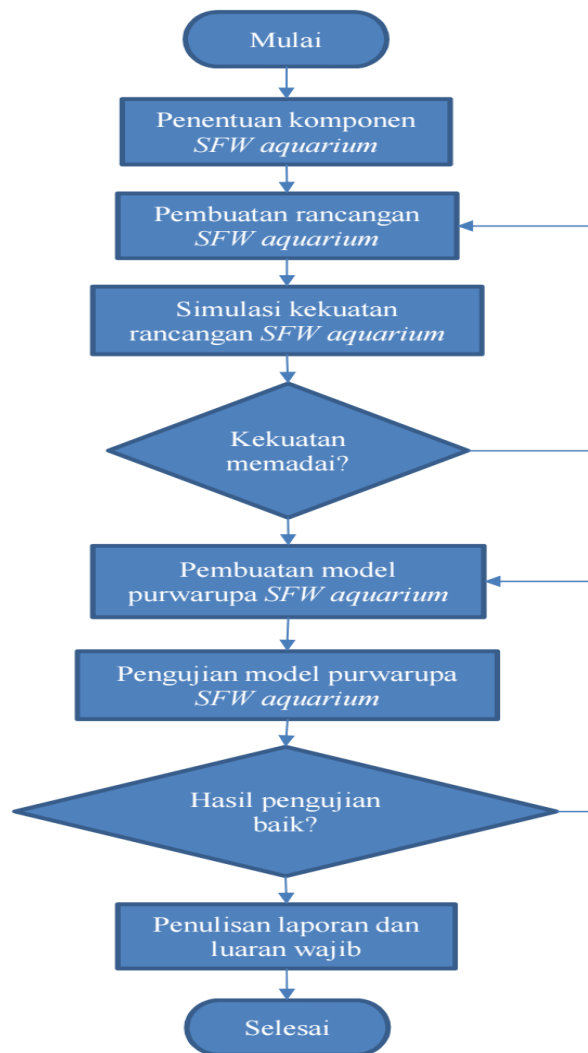

Figure 1. Research Flowchart

The flowchart above explains the research procedures to be carried out as follows:

Table 1. Research Stages

No	Activity	Description	PIC	Achievement Indicators	Exterior
1	Preparation for determining the components	Conduct a review of the latest literature to determine the components required for	1. Amril 2. Febi	1. Component specifications are determined 2. Material specifications	SFW aquarium component and material specifications.

No	Activity	Description	PIC	Achievement Indicators	Exterior
	of the SFW aquarium	designing a SFW aquarium.		are determined	
2	Implementation of the SFW aquarium design	Designing a SFW aquarium with the help of Autodesk Inventor software.	1. Kaminton 2. Mukhlis	The design drawings have been made.	SFW aquarium design drawing.
3	SFW aquarium design strength simulation	Conducting a strength simulation on the results of the SFW aquarium design with the help of Autodesk Inventor software.	1. Febi 2. Mukhlis	The design strength meets the necessary requirements.	Strength simulation results.
4	Making a prototype model of the SFW aquarium	Conducting the creation of a prototype model of the SFW aquarium based on the simulated design results..	1. Kaminton 2. Amril	The prototype model of the SFW aquarium has been created and all components assembled..	SFW aquarium prototype model ready for testing.
5	Data collection of the SFW aquarium prototype model	Conduct visual and functional testing on the SFW aquarium prototype model that has been created.	1. Kaminton 2. Febi	Pengujian visual dengan tingkat kepuasan pengguna $\geq 80\%$ Pengujian fungsional, semua komponen berfungsi dengan baik.	Hasil pengujian visual dan fungsional.
6	Writing reports and outputs is mandatory	Making a final report and being responsible for the research results	1. Kaminton 2. Amril 3. Febi 4. Mukhlis	Research reports and outputs must be completed and submitted to P3M.	1. Report 2. Journal Paper

The data analyzed in this study included strength simulation results, visual testing results, and functional testing results. The data analysis techniques used were as follows:

1. Strength simulation results

The strength simulation of the SFW aquarium design was performed using Autodesk Inventor software. Two simulation results were used as references: Von Mises Stress and Displacement. The Von Mises Stress simulation was used to determine the stress value that occurs in the material due to the overall load of the aquarium after it is filled with water, ornaments, and other components. If the stress value is still below the material's allowable stress, the design can be considered strong enough and meets the requirements for construction. Meanwhile, the displacement simulation was used to determine the extent of material displacement due to the load. If the displacement does not occur or is still below

the material's elasticity value, the design material can be considered adequate and meets the requirements for construction (Kumar *et al.*, 2021).

2. Visual test results

Visual testing was conducted using 100 randomly selected respondents from the academic community of the Kupang KP Polytechnic. Respondents were asked to assess the performance based on assessment items, each scored from 1 to 5, with 1 indicating dissatisfaction and 5 indicating high satisfaction. The SFW aquarium prototype model was considered successful if the satisfaction level achieved was at least 80% (Darmawan *et al.*, 2022).

3. Functional test results

Functional testing was conducted by running each SFW aquarium component for one month, then checking the water condition and fish health both before and after operation. The functional testing results were considered successful if no component damage occurred during the test, and the water condition and fish health were maintained (Khoriri *et al.*, 2024).

Table 2. Research Implementation Schedule

No	Activity Name	Month to -						
		1	2	3	4	5	6	7
1	Literature Study	■	■	■	■	■	■	■
2	Determination of SFW aquarium components	■						
3	SFW aquarium design creation		■					
4	SFW aquarium design strength simulation		■					
5	Making a prototype model of the SFW aquarium			■	■			
6	Testing of the SFW aquarium prototype model					■	■	
7	Writing reports and outputs is mandatory							■

RESULT

The SFW aquariums were designed with the same volume as standard aquariums, but with a slimmer width. The standard aquariums chosen were 60 liters and 34 liters. Therefore, the SFW aquariums used a width of 10 cm. The length and height were then adjusted to the target volume. Therefore, SFW aquariums were chosen with dimensions of 100 x 10 x 60 cm and 80 x 10 x 40 cm.

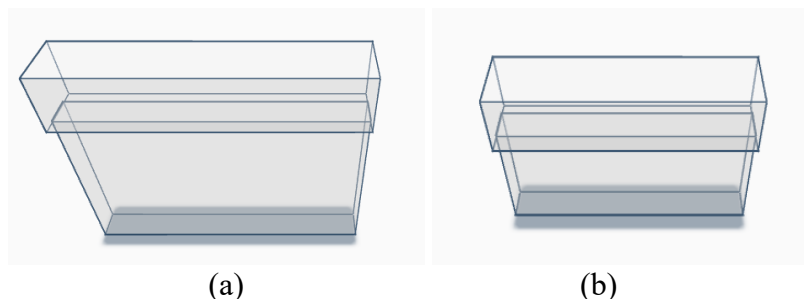

Figure 2. SFW Aquarium Design: (a) 100×10×60 cm (b) 80×10×40 cm



(a)

(b)

Figure 3. SFW aquarium prototype: (a) 100×10×60 cm (b) 80×10×40 cm

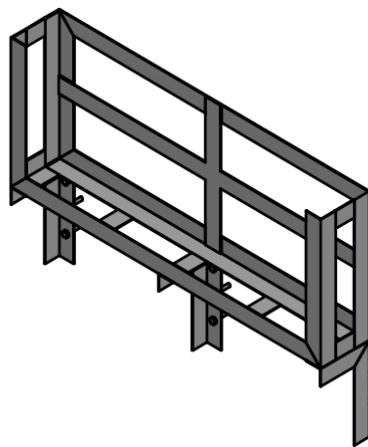

Gambar 4. Bracket SFW aquarium

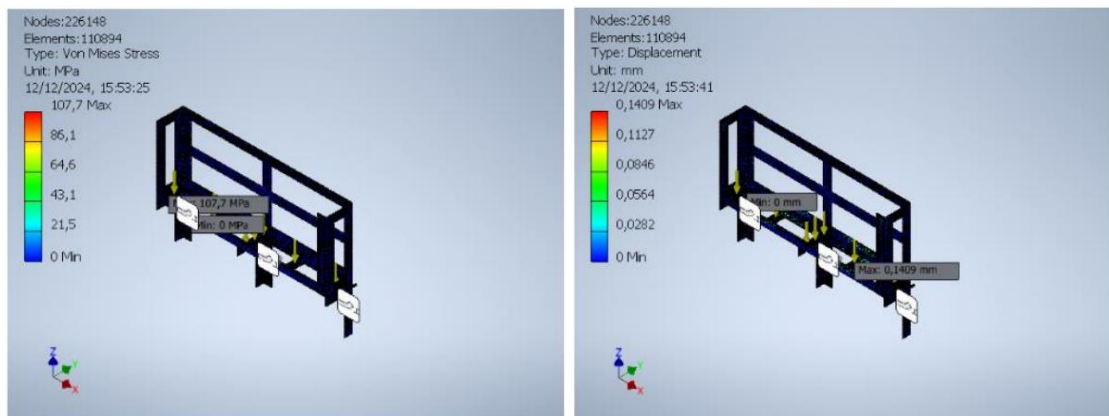

Figure 5. Simulation results of the strength of the SFW Aquarium bracket 80×10×40 cm

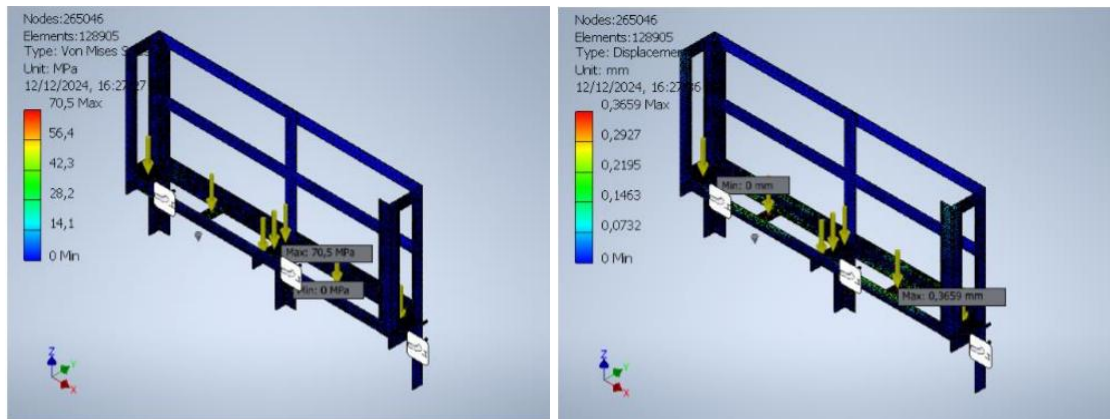

Figure 6. Simulation results of the strength of the SFW Aquarium bracket 100×10×60 cm



Figure 7. Visual testing of SFW Aquarium 80×10×40 cm



Figure 8. Visual testing of SFW Aquarium 100×10×60 cm

Table 3. Results of the SFW Aquarium Visual Testing Survey

No.	Assessment Items	Scoring					Satisfaction Level (%)
		1	2	3	4	5	

	Function					
1	Visual clarity		11	42	47	87,2
2	Ease of Maintenance		21	45	34	82,6
3	Efficient Use of Space		5	18	77	94,4
4	Structural Stability		38	42	20	76,4
5	Function as a Habitat		15	27	58	88,6
	Aesthetics					
6	Design and Appearance		24	49	27	80,6
7	Integration with Interior		33	52	15	76,4
8	Lighting		28	39	33	81,0
9	Design Creativity		25	41	34	81,8
10	Visual Comfort		12	26	62	90,0
	TOTAL		212	381	407	83,9

:



Figure 9. Condition of SFW Aquarium 80×10×40 cm on December 31, 2024



Figure 10. Condition of SFW Aquarium 100×10×60 cm on December 31, 2024

Table 4. Results of the SFW Aquarium Visual Testing Survey

No.	Assessment Items	Scoring					Satisfaction Level (%)
		1	2	3	4	5	
	Function						
1	Visual clarity			11	42	47	87,2
2	Ease of Maintenance			21	45	34	82,6
3	Efficient Use of Space			5	18	77	94,4
4	Structural Stability			38	42	20	76,4
5	Function as a Habitat			15	27	58	88,6
	Aesthetics						
6	Design and Appearance			24	49	27	80,6
7	Integration with Interior			33	52	15	76,4
8	Lighting			28	39	33	81,0
9	Design Creativity			25	41	34	81,8
10	Visual Comfort			12	26	62	90,0
	TOTAL			212	381	407	83,9

DISCUSSION

Strength Simulation Results

Mounting a SFW aquarium on a wall requires a bracket with sufficient strength. Therefore, a bracket was designed to hold the SFW aquarium. The bracket design used is shown in Figure 7 below: The bracket designs for the two SFW aquariums with different volumes differ in length and height. These designs were then subjected to simulation testing using Autodesk Inventor.

From the strength simulation above, it was found that for the 80x10x40 cm SFW aquarium bracket, the maximum stress (Von Mises stress) reached 107.7 MPa and the strain (displacement) was 0.1409 mm. This stress is still far below the material's yield stress of 207 MPa. Therefore, the stress applied by the SFW aquarium to the bracket is still safe. The strain is also very small and will easily return to its original shape when the load is removed.

For the 100×10×60 cm SFW Aquarium bracket, the highest stress (Von Mises Stress) reached 70.5 MPa and the strain (displacement) was 0.3659 mm. Because the bracket material used is the same, it can be seen that the stress that occurs in the bracket is much lower than the yield stress, and the strain that occurs is also very small, below 0.5 mm.

Visual Test Results

Visual testing was conducted by installing a SFW Aquarium on the wall of the Marine and Fisheries Polytechnic Workshop at Kupang. The installed SFW Aquarium was then compared to a regular aquarium, and respondents then assessed its functional and aesthetic value. The installed SFW Aquarium is shown in Figures 10 and 11 below.

The visual testing was conducted by administering a survey to 100 respondents, who assessed the SFW Aquarium based on its functionality and aesthetics. The survey results are shown in Table 5 below. The survey results above show that the visual testing showed an average satisfaction level of 83.9%. Since this result is above 80%, it can be concluded that the visual testing successfully achieved the desired level of satisfaction.

Functional Test Results

Functional testing was conducted for one month, from December 1 to 31, 2024. The test results showed that the SFW Aquarium was still functioning well on December 31, 2024, as shown in Figures 12 and 13 below:

From these two figures, it can be concluded that the SFW Aquarium is functionally functioning well.

CONCLUSION

The strength simulation results of the SFW Aquarium bracket show that the Von Mises stress of the two SFW Aquariums is 107.7 and 70.5 MPa, respectively, which is still below the material's yield stress of 207 MPa. This indicates that the bracket's strength is still adequate to support the SFW Aquarium. The visual testing results show that the average respondent satisfaction level reached 83.9%. This indicates that the SFW Aquarium visually meets the needs of aquarium enthusiasts.

ACKNOWLEDGEMENT

We are grateful for the close collaboration between the fisheries mechanization and aquaculture study programs in completing this study. We thank the Director, fellow lecturers, and all laboratory staff for their participation and assistance during the fieldwork.

REFERENCES

- Abda, J., Fernando, R., Sindhu, N., Rusdiana, V., & Leony, T. (2022). Rumah Minimalis Berkonsep *Green Building*. *Jurnal Orbith*, 18(3), 207-215.
- Alderton, D. (2019). *Encyclopedia of Aquarium and Pond Fish*. London: Dorling Kindersley.
- Arif, A. S. M., Nusrat, S., Uddin, M. S., Alam, M. T., & Mia, M. R. (2018). Hobbyist's Preferences and Trends in Aquarium Fish Business at Sylhet Sadar Upazila, Bangladesh. *International Journal of Fisheries and Aquatic Studies*, 6(4), 392-398.
- Brandao, M. L., Dorigao-Guimaraes, F., Bolognesi, M. C., Gauy, A.C.D.S., Pereira, A.V.S., Vian, L., Carvalho, T.B., & Goncalves-de-Freitas, E. (2021). Understanding Behavior to Improve the Welfare of An Ornamental Fish. *Journal of Fish Biology*, 1-14.
- Clements, H., Valentine, S., Jenkins, N., Rankin, J., Baker, J.S., Gee, N., Snellgrove, D., & Sloman, K. (2019). The Effects of Interacting with Fish in Aquariums on Human Health and Well-Being: A Systematic Review. *PLoS ONE*, 14(7), e0220524.
- Darmawan, M., Soewono, A. D., Hutagalung, R. A., Christiand, & Hermansyah, F. D. (2022). Rancang Bangun Sistem Pembersih Akuarium untuk Penjual Ikan Hias Jakarta Aquatics. *Jurnal Pengabdian Masyarakat Charitas*, 2(2), 1-11.
- Eggers, J. P. (2015). Reversing course: Competing Technologies, Mistakes, and Renewal in Flat Panel Displays. *Strategic Management Journal*, 37(8), 1578-1596.
- Haidar, S. T., & Andreswari, D. (2019). Sistem Pendukung Keputusan Pemilihan Desain Rumah Minimalis 3D dengan Menggunakan Analytical Network Process Berbasis Web. *Jurnal Rekursif*, 7(1), 10-21.
- Kang, J., Martinez, C. M. J., & Johnson, C. (2020). Minimalism as A Sustainable Lifestyle: Its Behavioral Representations and Contributions to Emotional Well-Being. *Sustainable Production and Consumption*, 27, 802-813.
- Khoriri, D. N., Hermawan, A. C., Aribowo, W., & Wardani, A. L. (2024). Rancang Bangun Akuarium dengan Pengkondisian PH Air Otomatis Berbasis PLTS. *Jurnal Sistem Kelistrikan Elposys*, 11(1), 51-55.
- KKP. (2024). 5 Program Prioritas Berbasis Ekonomi Biru di Tahun 2024,
- KKP. (2020). Peraturan Menteri Kelautan dan Perikanan Republik Indonesia Nomor 17/PERMEN-KP/2020 tentang Rencana Strategis Kementerian Kelautan dan Perikanan Tahun 2020-2024. Jakarta: Ditjen Peraturan Perundang-undangan Kemenkumham RI.
- Kumar, V. N., Bhaskar, S. U., Bharghav, J., Babu, V. A., & Rao, K. V. (2021). Design and Stress Analysis of a Four Blade Marine Propeller. Project Report. Mechanical Engineering Department. *Anil Neerukonda Institute of Technology & Sciences*. Visakhapatnam, India.
- Li, H., Hu, R., Alhashim, I., & Zhang, H. (2015). Foldabilizing furniture. *ACM Trans. Graph*, 34(4), 90-100.
- Lin, Y. B., & Tseng, H. C. (2019). *FishTalk: An IoT-Based Mini Aquarium System*. IEEE Access 7.
- Liu, J., Prouzeau, A., Ens, B., & Dwyer, T. (2022). Effects of Display Layout on Spatial Memory for Immersive Environments. *Proceedings of the ACM on Human-Computer Interaction*, 6 (76), 468-488.
- Maceda-Veiga, A., Dominguez-Dominguez, O., Escribano-Alacid, J., & Lyons, J. (2014). The Aquarium Hobby: Can Sinners Become Saints in Freshwater Fish Conservation?. *Fish and Fisheries*, 17(3), 860-874.
- Marchio, E. A. (2018). The Art of Aquarium Keeping Communicates Science and Conservation. *Front. Commun*, 3(17), 1-9.
- Puspita, E. (2019). *Ragam Desain Akuarium Penghias Interior Rumah*. Yogyakarta: Noktah.

- Raja, K., Aanand, P., Padvathy, S., & Sampathkumar, J.S. (2019). Present and Future Market Trends of Indian Ornamental Fish Sector. *International Journal of Fisheries and Aquatic Studies*, 7(2), 06-15.
- Savira, A. (2020). 5 Desain Ruang Keluarga Kecil yang Nyaman di Rumah Minimalis. Diakses 9 Maret 2024.
- Setiabudi, G. P. (2023). Perancangan Transformable Aquarium Memudahkan Proses Pemindahan Mencegah Risiko Kerusakan [*Skripsi*]. Program Sarjana Desain Fakultas Seni Rupa. Institut Seni Indonesia. Yogyakarta. 102 hlm. (Tidak diterbitkan).
- Spittell, C. (2019). The Effect of Virtual Versus Live Aquarium Viewing on Induced Stress Reduction. *Electronic thesis or dissertation*. Ohio Dominican University.
- Stevens, C. H., Croft, D. P., Paul, G. C., & Tyler, C. R. (2017). Stress and Welfare in Ornamental Fishes: what can be Learned from Aquaculture?. *Journal of Fish Biology* 2017.
- Walster, C., Rasidi, E., Saint-Erne, N., & Loh R. (2015). The Welfare of Ornamental Fish in the home aquarium. *Companion Animal*, 20(5), 9-15.
- Widjaja, T. (2013). *Aquascape: Pesona Taman dalam Akuarium*. Jakarta: Agromedia Perkasa.